



November 2012

SPOKEN WHEELS

THE PRESIDENT'S MESSAGE

Well, it's almost the end of the year and it has gone very fast. I wish you all a very Happy Thanksgiving Holiday as we have much to be thankful for. Speaking of thanks; thanks to our Vice President, John McDannel for arranging a wonderful program for our October meeting with Mr. Allen Munnecke who gave a history of the Wrigley Mansion and the Rose Bowl and Parade. Unfortunately, Mr. Munnecke passed away shortly after our meeting.

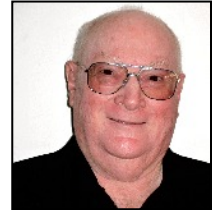

Thanks to all the men who participated in the seminar about installing a new "Teflon Tie Rod and Drag Link kit" on my car. It was nice to see some of our newer members participating, including Joe Escandon, Jerry Lampassi, Jerry Jr. Lampassi, Wilbert Smith and John Spielmann.

Again, I am reminding all of our members to bring non-perishable food items to the November General Meeting or the Holiday Party. Your donations will be taken to the Foothill Unity Center where they will be distributed to needy families in the San Gabriel Valley. Unfortunately there are many families this year who are in need of food for the holidays. Our club has been involved in donating food items for many years. Please help!

Continued on page 4

GENERAL MEETING - Friday, November 30 - Arcadia Red Cross, 376 Huntington Dr., Arcadia.

PROGRAM - This month's program will be presented by one of our club members, Kim Rhode, an Olympic champion in women's skeet shooting who has won five medals in five Olympic appearances.

BOARD MEETING - Wednesday, December 12 at 7:00 PM - Temple City Hall.
Come join us and participate in the exciting discussions.

OFFICERS

President:
Mickey Fruchter 626-797-2048

Vice President:
John McDannel 626-791-3221

Secretary:
Elaine Perry 626-443-0638

Treasurer:
Carol Emanuelli 626-286-5267

BOARD of DIRECTORS

John Emanuelli 626-286-5267
 Don McBride 626-792-8652
 Ken Mallory 626-305-2418
 Nancy Sharpe 626-359-1751
 Joe Wilson 818-790-0995

COMMITTEE CHAIRS

Accessories:
Jerry Lampassi 909-899-6015

Activities Coordinator:
Don McBride 626-792-8652

Advertising:
Carol Emanuelli & Pete Henderson 626-286-5267 / 626-286-9497

Low End Boys:
Marlin Perry - Leader 626-443-0638
With: Ted Bruns, John Emanuelli, Louie Formia, Mickey Fruchter, Mel Gross, Dick Homet, Gene Reinhardt, Brad Balmot

Ladies' Day:
Vicky Balmot 626-303-3111

Membership:
Randy Harper 626-357-6442

Mileage Keeper:
Marlin Perry 626-443-0638

Phone Committee: Board of Directors

Raffle - Ladies':
Barbara Dawson 818-790-6592

Raffle - Men's:
Jack Dawson 818-790-6592

Raffle - 50-25-25:
Gail Boekenooogen 909-392-7334

Refreshment Host:
Marlin Perry, John Spielmann, Nancy Sharpe

Refreshment Sign-ups:
Vicky Bartlett 626-799-6338

Restorer Articles:
Keith Smith 661-298-0625

Roster:
Joe Wilson 818-790-0995

Seminars:
Marlin Perry 626-443-0638

So. Cal MAFCA Regional Representative:
Marlin Perry 626-443-0638

Spoken Wheels:
Editor - Joe Wilson 818-790-0995
Proof Reader - Bea Fruchter & Elaine Perry
Distribution - Elaine Perry & Sally Baquet

Sunshine Lady:
Sally Baquet 626-444-7604

Technical Director:
Bob Travis 626-574-0665

Tours Director:
Open

Webmaster:
Joe Wilson 818-790-0995

Youth Outreach:
John Emanuelli 626-286-5267

Santa Anita A's Mailing Address:
PO Box 660904 Arcadia, CA 91006
Web site - www.santaanitaas.org

SAA'S CALENDAR OF EVENTS

BIRTHDAYS & ANNIVERSARIES

November

30 - General Meeting - Arcadia Red Cross, 376 Huntington Dr., Arcadia.

December

2 - MAFFI Finished Car Viewing event, see page 4
10 - Ladies' Brunch - Annia's, El Monte Airport, 11:00 AM
12 - Board Meeting
15 - Christmas Party, see page 5
15 - Christmas lights tour, see page 5
20 - Men's Breakfast - Annia's, El Monte Airport, 9:00 AM
28 - No Meeting in December. Go to the party instead.

January

9 - Pasadena Historical Museum Tour
13 - Cable Airport Tour
25 - General Meeting, Annual Club Auction - SAVE YOUR STUFF

March

21 to 24 - Las Vegas Tour (Old Laughlin tour)

December Birthdays

3 - David Lutz, Ken Mallory
5 - Pat Utter
7 - Doug Nielsen
11 - Andy Sais
12 - Joann Smith
15 - Jerry Lampassi
16 - Joe Blaylock, Eric Sandberg, Debbie Rodriguez
17 - Dave Hancock, Gracie Fant, Barbara Farino
19 - Thurston LeVay
23 - Mel Gross
28 - Richard Loe
29 - Corinne Case
31 - Joe Principe, Carl Rogers, Elaine Perry

December Anniversaries

8 - AC & Josie Byrd
12 - Michael & Amy Sriro
16 - Chuck & Nancy Sharpe, John & Sue Chandler
18 - John & Dorothy Knox, Larry & Corinne Case
20 - Thurston & Ruth Ann LeVay

OTHER MODEL A CLUB EVENTS

THE SUNSHINE LADY - SALLY BAQUET

January

26 & 29 - Turlock Swap Meet, Turlock, CA

Thinking of you - Don McBride

Sympathy - Elsie Johnson

Get Well - Randy Harper and Toni Ryan

A Thank You Note:

Thank you for your outpouring of love, thoughts and prayers during the difficult time we had during our daughter, Lisa Islas', illness. Your support meant so much to us.

Tom and Sheri Johnson, Ernie Islas and children

A Thank You Note:

Dear Santa Anita A's. Thank you for the lovely card and words of support.

Elsie Johnson

NEW MEMBERS

Here are the new members who joined in the last six months. Welcome them to our club.



Joe Giocomarra

La Cañada, Joined October 2012
1931 Sport Coupe



Jim Kroeger

Pasadena, Joined October 2012
Looking for a Model A



James and Tracy Slater

Pasadena, Joined May 2012
1928 Tudor Sedan



AC and Josie Byrd

Montebello, Joined July 2012
1930 Tudor

FICTION & FACT

Ponder This

by Joe Wilson

Share Problems & Make Friends



Thinking back, it occurred to me I have gained many new friends as result of “bad experiences”, which aren’t really all that bad. What I mean is that if something goes wrong, working with others to “make things right” provides an an excellent opportunity to meet and know people better.

I can think of many examples involving Model A “bad experiences” requiring either mental or physical help which later were viewed as “good” events. Be it my car or someone else's, roadside repairs typically involve “group” trouble shooting . That is always a “bonding” experience.

Our recent Tech seminar at Marlin’s house was organized to “solve a problem” brought out some of our newer members and provided an opportunity for everyone to spend time with them, either working under the car or just “supervising”.

Helping Steve and Sondra salvage their luggage rack which fell off on the 14 Freeway during a tour last year got us better aquatinted, despite the trauma at the time. See photo on page 7.

Solving problems can be good for both you and your friends.

Good News at Last

by Cliff Mount

Have you ever walked into a room with some purpose in mind, only to completely forget what that purpose was?

Well, it turns out that the doors themselves are to blame for these strange memory lapses.

Psychologists at the University of Notre Dame have discovered that passing through a doorway triggers what’s know as an event boundary in the mind, separating one set of thoughts from the next.

Your brain files away the thoughts you had in the previous room and prepares a blank slate for the new locale.

It’s not aging, it’s the door.

Don’t you feel better now?

I received this note from fellow SAA’s member, Cliff Mount. I thought it should be shared with everyone in the club.

Food for Thought

by Joe Wilson

Every year we request that you bring food to our November meeting and our annual Christmas party for donating to the “Foothill Unity Center.” That sounds good, but who is that organization and what is their mission?

The Foothill Unity Center acts as a lifeline for very low income individuals and families who are struggling to survive. Their service area includes eleven cities in the San Gabriel Valley. Their services provide free food, crisis assistance and access to health care resources. In 2010, they helped 4,320 families (12,117 people).

In 2011 they distributed 3 million pounds of food and provided 5,790 health service incidents which included access to medical, dental and vision service in partnership with community providers. In August each year they, with the support of individuals, businesses and organizations, have provided children of client families with clothing and supplies needed to start the school year. On Thanksgiving and Christmas, food, toys and clothing are provided at their holiday distribution party at the Arboretum in Arcadia.

So, again this year we solicit your support. Bring your food donations to the November meeting. If you miss the meeting, you have a second opportunity at our annual Christmas party where you can deliver your donation directly to good old St. Nick himself.

Italian Cookie Bringers Of The Month Club

Norma Canzoneri, Patty Lampassi, Carol Emanuelli
(No doubt these will be Italian cookies w/ Chianti)

This month’s photographers include:

J. Wilson, Vicky Balmot

Think About It

Friends don’t let their Model A friends buy cars they don’t know how to help them fix.



FICTION & FACT

MAFFI Car is Finished

The MAFFI car is finished and will soon begin its final journey to the Model A Museum in Hickory Corners, Michigan. There will be an "open garage" at Bob Trousil's on Sunday, December 2nd at 10:30 AM. If you worked on the car over the past 5 years, or you feel you may never get to Michigan to see the project to which we have donated so many parts, hours and dollars, you are invited to see the treasure and trade a few tales of its restoration.

Please RSVP to Elaine Perry if you plan to attend (emp1931@yahoo.com or call 626-443-0638).

President's message continued-

Speaking of HELP and the Holiday Party, we need volunteers to help setup chairs and tables and decorate - - 9:30 AM at the Sierra Madre Methodist Church. There will be a signup sheet at the November meeting. Please join us for an hour or two. Thanks.

Congratulations to our members who celebrate their anniversaries of longevity in MAFCA. If you own a Model A Ford and are not already a member of the Model A Ford Club of America, I recommend that you join. It is a great organization.

MAFCA Bylaw changes

The MAFCA membership recently voted approval of two MAFCA bylaw changes recommended by the MAFCA board of Directors. Garth Shreading, MAFCA President commented on these proposed changes in a previous issue of the Restorer magazine.

One by-law change increases the time a former board member must wait before he can run again after he completes his term. The time off is increased from one year to two. The purpose of the change is too provide more opportunity for others to serve on the board.

The other by-law change relates to the qualifications of car clubs petitioning MAFCA to become chapters. Some clubs petitioning for membership were clubs whose membership consisted mostly cars other than Model A's. The wording in the by-laws stated that if the petitioning club met our organization's minimum requirements, the Board shall accept them as MAFCA members. The word "Shall" has been changed to "May".

MAFCA Longevity Awards

The November / December issue of the Restorer Magazine included a listing of the longevity awards for 2012 which show the names of members reaching the 55, 50, 45, 40, 35, 30 and 25 year membership milestones. Each member will receive a "Longevity Pin" reflecting the appropriate years of membership.

Below is a listing of the SAA's members who were recognized by MAFCA.

45 Years - Pete & Gloria Henderson
Gene & Julie Reinhardt
30 Years - Anthony & Kathy Catroppa
Jim Constantian
John & Betty Wilson
25 Years - Harold & Sally Baquet
Keith & Joann Smith

We congratulate and thank you for putting up with us "newcomers" in recent years.

Did You Vote?

On October 24, we were invited to help count votes at the MAFCA headquarters in La Habra. A total of 16 MAFCA members were on hand to count the results of the 3,798 vote cards turned in. The vote was for new Board of Directors and approval of two by-law changes.

Eleven members of the SAA's participated: Elaine & Marlin Perry, Bea & Mickey Fruchter, Jerry and Patty Lampasi, Joe & Joy Wilson, Nancy Stancil, Alan Bennett and Steve Kurtz.

The results of the election can be viewed on the MAFCA web site (mafca.com)



COMING EVENTS

Christmas Party

Saturday, December 15

As is our tradition, a club Christmas Party will be held at our traditional location, the Sierra Madre Methodist Church which is located, of all places, in Sierra Madre, 695 W. Sierra Madre Blvd., on the N.E. Corner at Michillinda, to be exact.

There will be good food and entertainment; you betcha. But, you do have some responsibility here; there is a commitment involved. Just make a **pre-paid reservation by December 10th**, preferably before. Santa is flying in the food and needs to know how much to load on his sleigh.

Either mail or hand deliver a check to Carol Emanuelli. She will be at our next meeting on Friday November 30th. That would be a good time to pay-up, if you are there.

Cost to you will be \$10.00 per adult, either a member or guest. Cost to any kids, your's or not (12 & younger) will be \$ 5.00 each. If they are unruly, there may be a surcharge. Santa will be the judge.

IMPORTANT NOTE:

Breaking with tradition, the traditional Christmas lights tour will be held just prior to our traditional Christmas party. So, this year you can get lost on the way to the party and rather than being late for the cookies at someone's house, you won't "Get to the Church On Time" to reserve your favorite seat. See tour details below:

Christmas lights Tour

Saturday December 15

by Bob Travis

Rain or Shine or even snow. We will assemble in COCO's (Michilinda) East parking lot at 4:30 PM. We will depart the West exit on to Michilinda - North bound, Then proceed to Hastings Ranch, tour as much as you like, leaving West bound on Sierra Madre Blvd to New York Ave toward Altadena, on to the "Balian House". From there on to "Christmas Tree Lane" and return to the Sierra Madre United Methodist Church in time for 6 PM dinner. Modern Cars are welcome. Contact Bob Travis if you have questions.

Pasadena Museum Train Tour

Wednesday, January 9

by Mickey Fruchter

TRAINS AND MORE TRAINS

There is a Santa Anita A's tour scheduled on January 9, 2013. **Part one:** we will drive to the Los Angeles Railroad Heritage Foundation (LARHF) office in Alhambra. They will also provide refreshments for us. They have a display and a presentation about the early history of the rail system in the Los Angeles/San Gabriel Valley area. **Part two:** we will have lunch on the way to our next stop. **Part three:** next stop is Pasadena Museum of History for an exhibit about the 'Red Car' lines in the San Gabriel Valley. Wednesday is free for residents of the Pasadena area. Be sure to bring I.D. on this tour as they may request verification of your residence.

There will be a sign-up sheet at the November General Meeting. We need a 'head count' for the LARHF (refreshments) and the restaurant. If you cannot attend the meeting and would like to join us, please call Mickey at (626) 797-2048 to be placed on the sign-up list.

We will leave the Ralph's Market parking lot on Huntington Drive at Michillinda Ave. at 9:30 a.m.

Cable Airport Airplane & Car Show Tour

Sunday, January 13

by John Emanuelli

Here's a chance to see old cars, old planes and old people in action. We have participated in the this event for a number of years. This is their 38 anniversary event. It is a two day show but we will participate only on Sunday the 13th.

Pay attention now; the show arrangements have been changed this year.

- The entrance fee is \$10 per car if you pre-register or \$15 at the gate.
- Show is limited to cars 1970 & earlier and will be limited to 175 total cars each day.
- Cars must be in place by 10:00 AM
- Cars may not exit the show between 10 AM to 12 PM, and between 12:30 PM to 3:30 PM.

We will meet and depart from the Citi Bank parking lot on the corner of 1st Ave. and Alta in Arcadia at 8:10 AM for a non-freeway drive to the airport.

John Emanuelli will lead the tour. He will have a sign-up sheet and a pre-registration form at the November general meeting.

PAST EVENTS

Ladies' Day

Saturday, October 20

by Vicky Balmot

We had a great day on Ladies' Day on October 20, 2012. Twenty five ladies and three gents joined us on the trip including Elaine and Tracy Perry, Nancy Stancil and Joe Principe, Judi Moore, Carol and John Emanuelli, Olive Moore, Julie Reinhardt, Gracie Fant, Mary Ann Sepulveda, Ruth Ann LeVay, Bea Fruchter, Joyce Travis, Vicky Bartlett, Patricia Lampassi, Elsie Johnson, JoAnn Formia, Jan Peterson, Patsy Harbicht, Gail Boekenooogen, Karen and Joe Blaylock and several guests.



We started our tour with a 12:00 noon Lunch at Robin's Restaurant in Pasadena which included chicken, hamburgers or macaroni and cheese. We left our cars for the day at Robin's parking lot. We arranged for a free bus (thank you Dick Canzoneri) to transport us to the Kodak (Dolby) Theater to see the Cirque du Soleil showing of "Iris"...a tribute to the movies. The bus driver was wonderful and dropped us right in the back of the theater. We all shopped for about an hour. We were each given \$5.00 to spend on dessert; most of us spent it on goodies from the candy shop next to the theater. We were treated to a terrific 90 minute show with great wonders on the stage and in the air with perfect views from our orchestra seats.

We then rode back in the luxury of the bus. The club provided us all with bottled water. We were able to all relax and talk while the bus driver navigated the traffic back to the restaurant where our tour ended at 6:45 PM. A few ladies managed to cat nap on the way back to the restaurant.

Thank you to all the ladies who joined us for such a fun day with friends!

Mountain Tour to Wrightwood

Friday or Saturday, Nov. 9th or 10th

For those of you who didn't sign up for this tour nor read their emails, but went anyway, we want to advise you - - **The tour was canceled** due to bad weather.

There is a good chance the tour will be re-scheduled, but don't do anything until you hear from the "Tourmeister".

Tech Seminar

Saturday, November 17

If you want to do a repair on your Model A and you are in a hurry — do the job by yourself. If you have plenty of time, then get a crew of 17 from the SAA's.



Mickey Fruchter wanted to install new style tie rod bushings in his car and suggested that we do it as a seminar. It was estimated that the installation and associated lecture would only take an hour at most, leaving the rest of the scheduled time open for conversation, donuts, coffee and lunch.

It turned out the job took five hours and involved 17 people. Granted, most of the participants were supervising, but they needed that many people there to consume 30 hot dogs, 5-6 pounds of potato salad and assorted drinks.

Yes, it was a learning experience. The next seminar will be on the art of tire inflation.

Seriously speaking, it was a good day and we had several of our newer members participating. Mickey did get his car fixed and his wheels aligned using two different speciality tools; another learning experience.

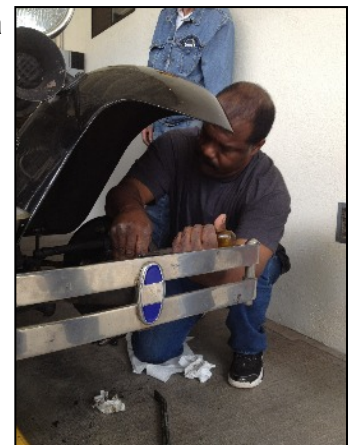

OTHER STUFF

Who invited these Guys Anyway?

Attending a Santa Anita A's Club meeting is a good way to get to know what our organization is all about. Here are a few candid photos taken at a recent general meeting. Judge for yourself.



Just be careful which night you invite guests.

If it isn't electrical or fuel, it must be a Mechanical Problem



Sondra & Steve Kurtz stop for a rest on their way home from a tour up North.

Reclining Bucket Seats for your Model A

by Jack Dawson

The front seats of our Model A's were never really comfortable and if you are not a purist, this article may help you from having to listen to your spouse complain.

The distance from door to door at the rear of the front seat is 47" and at the front of the seat it is 42". This limits you to individual seats that are not over 21" wide. Find seats with projecting steel feet that can be bent to be horizontal. Seats from a Mazda Protege' will work very well.

The sub frame for these seats can be made of clear 2 x 4's (1.5" x 3.5" cut down to 1.5" x 2.5"). Use vertical bolts to go through the 2.5" height, down to meet the existing tapped holes in your car. Mount the seats on this rectangular frame by drilling all the way through the 2.5" dimension. Countersink T-nuts on the bottom and bolt from the top. Do not use lag screws.

This arrangement now gives you a nice space under your seats for storing a lug wrench, jack, fire extinguisher and tools.

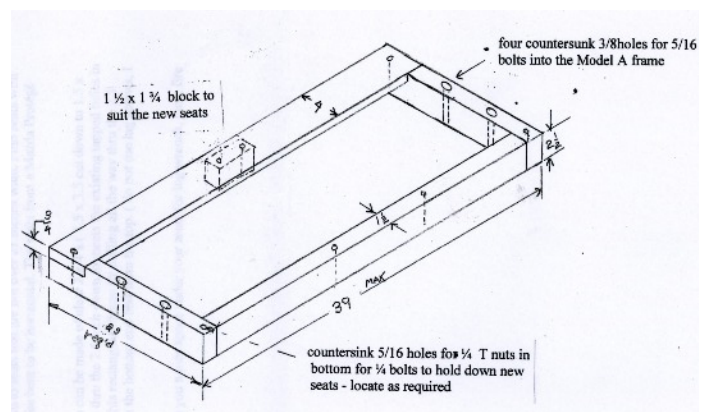



The following article is a reprint from the July 2012 issue of Hemmings Motor News. It provides some interesting insight into choosing an effective fire extinguisher for your vehicle.

Fire Extinguishers

There's more to protecting your classic than a trip to the hardware store.

BY TERRY McGEAN

When car enthusiasts seek fire protection, they tend to head to the nearest home store and buy a household, hand-held fire extinguisher, and then figure the situation is covered. The subject of fire suppression is actually fairly vast, but we'll touch on the basics as they apply to automobiles.

The aforementioned household extinguishers found at retail distributors are generally of the dry chemical type; this is the standard for fire suppression in the U.S., found in most residential and commercial dwellings. These units still provide a very effective means of putting out relatively small fires, and they work by essentially smothering the flames, physically cutting off the air required for combustion. Unfortunately, the chemicals used to make up the powder in these types of extinguishers are highly caustic, which means that they will have a negative impact on everything they come into contact with. In an automobile, that means that metals will be corroded, glass will be etched, and even "soft" materials like rubber and plastic can be affected. Most automotive repair experts will tell you that anything exposed to dry chemicals from a fire extinguisher will have to be replaced.

A less damaging alternative favored in the transportation industry for years is Halon, which is considered a clean agent gas. It works by displacing oxygen from the atmosphere so that combustion cannot continue. The version most commonly used today is Halon 1211, and though it is safe and effective, it also contains CFCs, and so has been banned from production worldwide. However, the product is still legal for use in the U.S. and is still available, at least until stockpiles run out. There are other clean agent gas extinguisher products available today that are

environmentally friendly, though so far, none is as effective as Halon.

Yet another option for supplemental fire suppression is foam, which has actually been used in various forms since the early part of the 20th century. Most people are familiar with fire-fighting foam for its use in the aviation industry. Currently, one of the most commonly used versions is aqueous film-forming foam (AFFF), which was developed by the U.S. Navy in the 1960s. This is a water-based product that spreads over hydrocarbon-based liquid fuels quickly providing a layer of water underneath the foam that cools the fuel to stop the formation of vapors, which suppress combustion. Because of its ability to stick to the surface, it is sprayed on. AFFF is particularly effective at suppressing fire in moving vehicles. Although foam may appear to make a huge mess when deployed, AFFF is actually non-toxic and non-corrosive and after doing its job, the residual is simply hosed off and washed down a drain.

Like dry chemical systems, Halon and foam are also available in handheld containers, though they are more difficult to source. We recently discovered Fire Fight (www.firefightproducts.com), (321- 299-5707), a company that specializes in various supplemental fire suppression systems, offering multiple options for automotive applications, including Halon and AFFF in conventional coin-pact extinguisher containers that can be mounted in a vehicle. Fire Fight also offers an interesting alternative in the form of "passive auto deploy" fire-suppression systems that couple a heat-sensitive trigger to a compact suppressant container; when the trigger sensor experiences a pre-determined temperature, the suppressant is expelled automatically even if you're not there.

MARLIN'S MUSINGS

By Marlin Perry



MARLIN'S MUSINGS

We all thank last month's refreshment providers. They were outstanding, Carolyn McBride's big Chocolate bundt cake, Gail Boekenoogen's Pumpkin dessert and Chocolate chip cookies and Diana Kincart with a super special cookie. Did the sugar flow!.

Well, the word is out Vicky Bartlett is President of the Diamond Tread Chapter. Heads up Vicky.

AC Byrd and his wife Josie are on a 14-day cruise. Congratulations.

Louie and Jo Ann are celebrating 50 years of marriage. Ten family members are celebrating on a cruise. Oh happy days, lovers.

How about Dick Homet, he took a trip to Cuba. Good going Dick.

Want to know one smart man? How about Scott Bonner. He took the State Bar exam and passed the first time. Does this mean Mickey gets a new lawyer instead of his brother?

Looking for Ted and Paulette, they are back in the desert with the snowbirds.

John Spielmann and Marlin thank Nancy Sharpe for looking out for us with club refreshments. Thanks.

Well after two pages of what to do, Bob Moore along with Ken Mallory got Wilbert Smith's nice Coupe to the brake shop on Bob's trailer. The Coupe will stop after the hydraulic brakes are fixed. Oh, the two pages are suggestions for Wilbert to work on his car.

Elaine and I want to thank Steve Newton and Vicky Bartlett; they totally surprised us at the Southern California Regional meeting with a Model A Club of America service award. This was from Screenland A's and the Diamond Tread clubs. I was very humbled by it. Thank you both.

SEMINAR NEWS

This month found us fixing AC's horn; it is blowing good now. We got AC learning about the horn and wiring. He really got a nice Pickup truck. Mickey got Vicky's rear additional stoplight wired and working bright. Bob Travis adjusted her brakes; he is our club expert on brakes. Thanks Bob.

On Saturday the 17th we had 17 club members at a seminar on installing an EZ steer kit on Mickey's Pandora. The car that has gone almost 100,00 miles.

Mickey's concern was it would only take 2 hours, did he get surprised it took 5 hours. Even with the best Model A mechanics his car. Pandora showed all why it's name is Pandora. It all worked out well with a big, big hammer and hanging in with all at work. Thanks to all and to my daughter Tracy for lunch.

PS They say Model A's are easy to work on.

Jim Austin got drafted for a day with the Low End Boys; going out to John Knox's to put in a head gasket. Thanks Jim. John has a beautiful car and a nice ranch home.

For Sale

1926 Model T C-Cab Stake Truck with extra parts. \$3,500 OBO

1978 MG Midget, Low miles. \$3,500 OBO

1921 Federal Flat Bed Treuck, new tires. \$750

Two Fordson Tractors. \$750 each

Five "Hit & Miss" engines, restored. \$750 each

Large antique sawmill with 6 HP Fairbanks hit and miss engine. \$1,500

1952 MG TD, excellent original. Inquire

Large collection of radio controlled airplanes and engines, including a 5 cylinder radial engine.

Photos and more info on request.

Contact Sheldon Ball 209 966-3759

herrball@sti.net

"Kool-Feet"
INSULATED MUFFLER SHIELD
77 DEGREES OF HEAT REDUCTION
 Heavy Duty Construction
 \$79.95
 Leslie Pam (310) 275-3836
 LAKOOLP@pacbell.net

Model "A" Oil Filter System



Made in U.S.A.
 Precision machined
 Does not restrict oil flow
 Filter does not drain down
 Increases the life of your engine
 Lengthens the time between oil changes

Tom Johnson
 (626) 446-3367
 tomjohnson149@yahoo.com

CLASSIC TIRES
 Great selection. Best prices.
We can save you money!
FREE CATALOG



Lucas
 AUTOMOTIVE

2850 Temple Ave. Long Beach, CA 90806
 www.lucasclassictires.com **800-952-4333**

PROTECT YOUR ANTIQUE
 WITH J.C. TAYLOR



J.C. Taylor
 INSURANCE

50 Years Experience
 Agreed Value Coverage
 Superior Claims Service

1-888-ANTIQUÉ www.jctaylor.com

Order Online
 request 200 page
FREE catalog



Gaslight
 Auto Parts
 Urbana, Ohio
800.242.6491
 www.gaslightauto.com

Antique Automotive Industries
New Parts For Old Cars

REPRODUCTION PARTS AND SUSPENSION COMPONENTS
SPECIALTY FORD PARTS



JIM GORDON
 SALES MANAGER

9109 GARVEY AVE
 ROSEMEAD, CA 91770 - USA
 (626) 288-2121

MM MITCHELL MANUFACTURING



Sue • Steve • Cyndi
 Mitchell
Mitchell MFG.
 530-458-4500 800-859-2088

FORD OVERDRIVES/UNDERDRIVES 1928-1948
 MODEL A FORD SYNCHRONIZED-TRANSMISSION VINTAGE CAR OVERDRIVES

P.O. Box 925 1157 Parker St. Colusa, CA 95932

We've Revolutionized the way you find Model A Parts!

FOUR CATALOGS TO CHOOSE FROM:
 • Coupe • Pickup • Open Car • Sedan

CALL & ORDER YOUR FREE CATALOG TODAY
AND ASK ABOUT OUR MONTHLY SPECIAL!

1-888-879-6453
 www.mikes-afordable.com



YOUR MOST RELIABLE SUPPLIER OF QUALITY PARTS FOR OVER 15 YEARS!
 We Ship Worldwide!

bryant **Carrier**

CALIFORNIA COOL
 HEATING, AIR CONDITIONING
 AND FILTRATION

SCOTT HAGEN

SALES, SERVICE AND INSTALLATION FOR PRIORITY SERVICE
 CELL 562 900-3219

KENNETH A. JONES
 CERTIFIED PUBLIC ACCOUNTANT

4565 INDUSTRIAL ST., #7B
 SIMI VALLEY, CA 93063
 TELE: 626-590-5806
 FAX: 805-578-6801
 EMAIL: KENAJONES@EARTHLINK.NET
 OR
 BUTTUGLYCPA@YAHOO.COM

EARLY FORD STORE
of California
www.earlyfordstore.com

Specializing in Rare Parts and Accessories for Early Fords 1928/1972 Passenger Car & Pick-Up



San Dimas, CA 91773
108 W. Bonita Ave.
Tel: (909) 305-1955
Fax: (909) 305-1953

The World's Largest Selection of 1909-31 Ford Parts

Snyder's
ANTIQUE AUTO PARTS

12925 Woodworth Rd. • New Springfield, OH 44443
Toll Free Ordering (888) 262-5712
or FAX (888) 262-5713
Order On-Line @ www.snydersantiqueauto.com



 **FREE Fully Illustrated CATALOG**
\$10.00 outside the U.S., Canada, & Mexico

RODERICK Realty
(626) 675-0660

JIM & JAN
RODERICK
DBK Lic. #OH49743
jimjanroderick@gmail.com

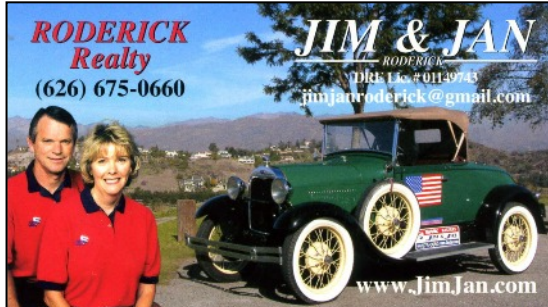

www.JimJan.com

TIN SHED
MACHINE SHOP AND
ANTIQUÉ AUTO REPAIR

Larry Blair aka "LOCO LARRY"

9110 Dice Road Shop: 562-941-6131
Santa Fe Springs, CA 90670 Home: 562-693-2252
E-Mail: Locolarry07@verizon.net



PAUL'S AUTO REPAIR
ASE CERTIFIED - FOREIGN AND DOMESTIC CARS
Paul J. Vitelli, Owner/Mechanic
626.969.7711

710 Georgia Ave.
Azusa, CA 91702
Mon. - Fri. 8 a.m. - 5:30 p.m.



VW SPECIALIST Early-Late Model also
BMW Volvo Honda Toyota Nissan
GM Ford Chrysler

Aries Restoration & Repair

Model A Fords – Our Specialty
Exhaust Systems for the Model A Ford
(visit www.Amuffler.com)
Award-Winning Paint and Body Work

Since 1983

Joe Davis, 650-948-6424
jdavis@Amuffler.com
Aries Limited • La Honda, CA



Kenny Sandblasting Inc.
9625 E. RUSH STREET
SO. EL MONTE CA 91733-1782

KEITH SHAPIRO (626) 443-8876



ARIZONA MODEL A, L.L.C.

- NEW PARTS
- USED PARTS
- SERVICE
- RESTORATION
- HOUR: TUES-FRI 9-12, 1-5
SAT & EVES BY APPOINTMENT

SAMUEL P. GUTHRIE

15838 S. GILBERT RD., CHANDLER, AZ 85225
(480) 782-0266



EL MONTE PLATING CO.

DARREL JENSEN (626) 448-3607
FAX (626) 448-2309



Foreign Motors
BODY SHOP.com

Dennis Rummens OWNER/MANAGER
(626) 287-2404 PHONE (626) 287-0828 FAX
9436 Las Tunas Drive . Temple City . Ca . 91780

Find us on Facebook



NEXT GENERAL MEETING - November 30 ARCADIA RED CROSS HEADQUARTERS

Important Things to Do and Remember:

1. Save all those Christmas presents you don't like and bring them to the January Club Auction.
2. Be sure to sign-up and show-up for all the events the club offers.
3. Find one of the new members and tell them that you are glad they want to participate.

WEAR YOUR SAA's NAME BADGE TO MEETINGS AND EVENTS



PO Box 660904
Arcadia, CA 91006-0904
www.santaanitaas.org

